

## ASSEMBLY GUIDE

### **DX-TVM111**

TV Wall Mount

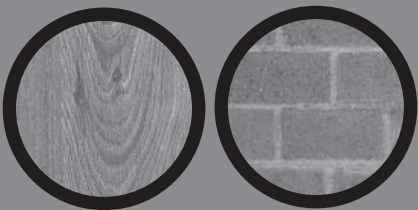

For either wood-stud or  
concrete wall installations

Safety information and specifications .....	2
Tools needed .....	2
Package contents .....	3
Installation instructions .....	4

## Safety information and specifications



### IMPORTANT SAFETY INSTRUCTIONS - SAVE THESE INSTRUCTIONS

**CAUTION:** Do not use this product for any purpose not explicitly specified by Dynex. Improper installation may cause property damage or personal injury. If you do not understand these directions, or have

doubts about the safety of the installation, contact Customer Service or call a qualified contractor. Dynex is not responsible for damage or injury caused by incorrect installation or use.

The weight of your TV must not exceed 30 lbs. (13.6 kg). The wall must be capable of supporting five times the weight of your TV and wall mount combined.

This product contains small items that could be a choking hazard if swallowed. Keep these items away from young children!

**Maximum TV weight:** 30 lbs. (13.6 kg)

**Screen size:** 13 in. to 26 in. diagonal

**Overall dimensions (H x W):**

5.4 x 8.7 in. (13.7 x 22 cm)

**Wall-mount weight:** 1.7 lbs.

**We're here for you**

[www.dynexproducts.com](http://www.dynexproducts.com)

For customer service, call:

800-305-2204 (U.S./Canada markets)

## Tools needed

You will need the following tools to assemble your new TV wall mount:

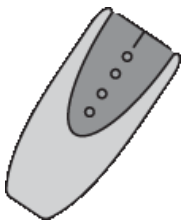

Edge-to-edge stud  
finder



Pencil

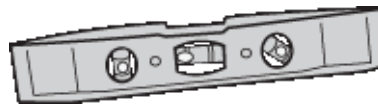

Level

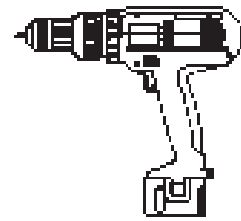

Drill



Phillips screwdriver

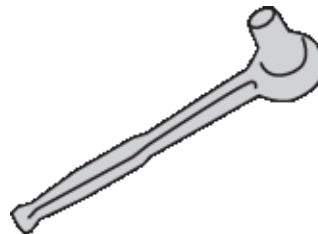

Socket wrench with  
7/16" (11 mm) socket or  
adjustable wrench

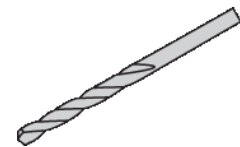

1/8" (3 mm) wood drill bit for  
wood stud wall

OR

1/2" (12 mm) masonry drill  
bit (concrete only)

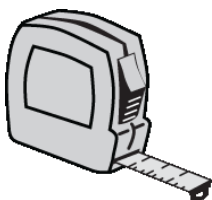

Measuring tape



Tape



Hammer

## Package contents

Make sure that you have all the hardware necessary to assemble your new TV wall mount:





**A** TV Bracket (1)

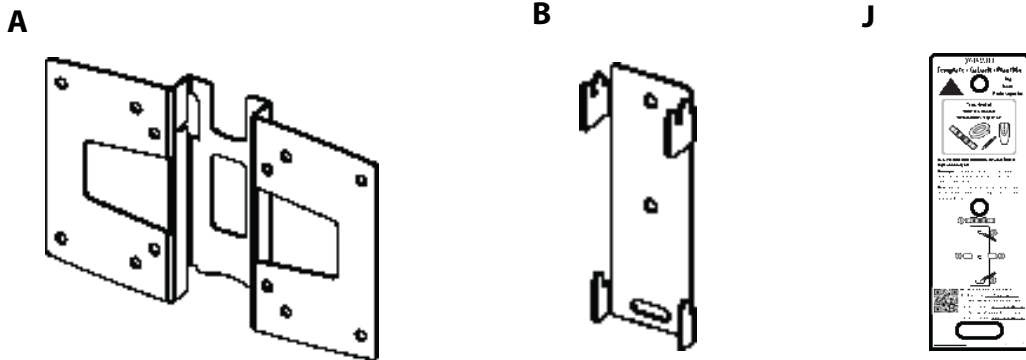

**B** Wall Plate (1)

**J** Wall mount template (1)

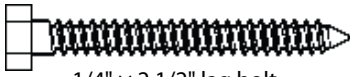
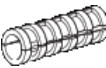

## TV Hardware Bag

Label	Hardware	Qty.
<b>C</b>	 M4 × 12 mm screw	<b>4</b>
<b>D</b>	 M4 × 30 mm screw	<b>4</b>
<b>E</b>	 M4 washer	<b>4</b>
<b>F</b>	 M4 spacers	<b>4</b>

Label	Hardware	Qty.
<b>G</b>	 1/4" × 2 1/2" lag bolt	<b>2</b>
<b>H</b>	 Concrete anchor	<b>2</b>
<b>I</b>	 Locking bar	<b>1</b>

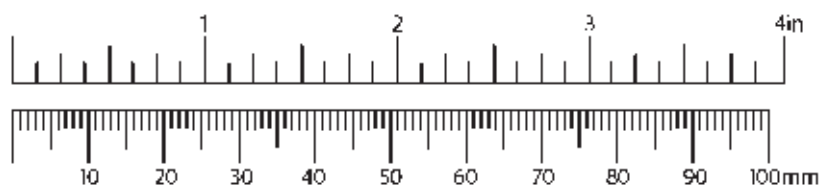

## Installation instructions

### STEP 1 - Determine wall-mount location

#### Notes:

- For more detailed information on determining where to drill your holes, visit our online height-finder at: <http://mf1.bestbuy.selectionassistant.com/index.php/heightfinder>
- Your TV should be high enough so your eyes are level with the middle of the screen. Normally, 40 to 60 inches from the ground.

The center of your TV will match the center of the wall plate (**B**). Before you drill holes in the wall:

- 1 Measure the distance from the bottom of your TV to the middle (half of the height of the TV). This is measurement **a**.
- 2 Measure the distance from the floor to where you want the bottom of the TV to be placed on the wall. Keep in mind that the bottom of the TV should be placed above any furniture (such as entertainment centers or TV stands). The TV should also be above items placed on top of the furniture (like a Blu-ray player or cable box). This measurement is **b**.
- 3 Add **a + b**. The total measurement is the height where you want the center of the wall plate (**B**) to be on the wall.
- 4 Use a pencil to mark this spot on the wall.

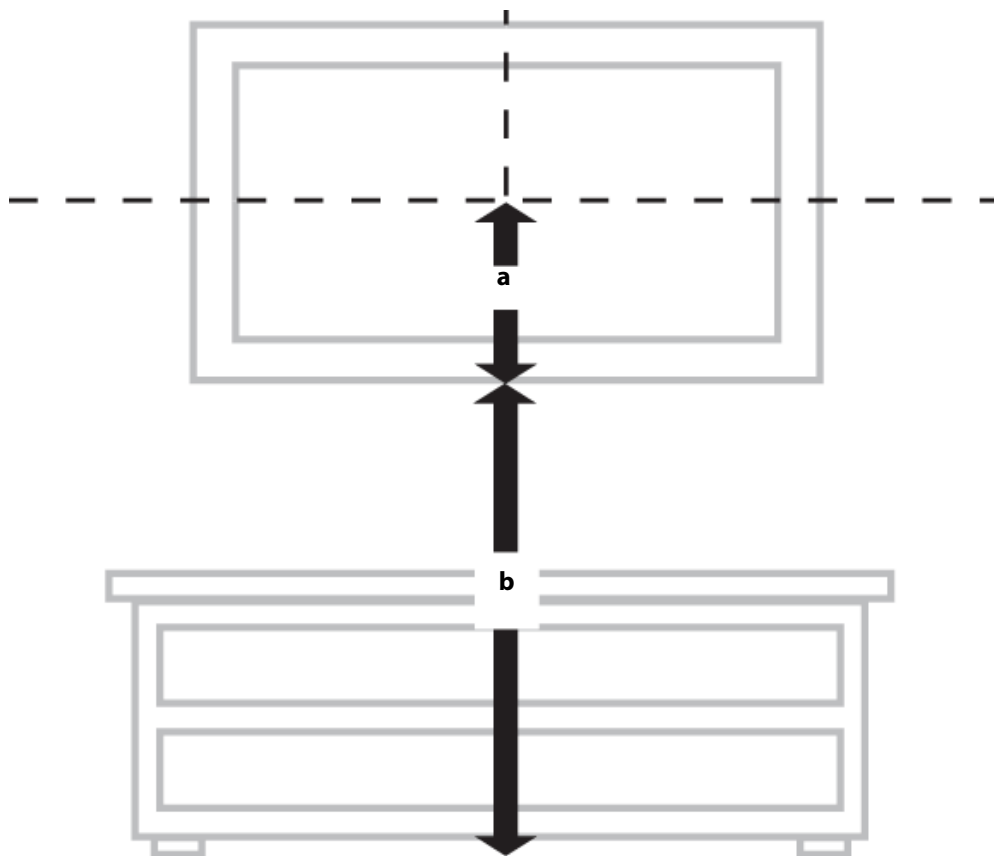

#### You'll need

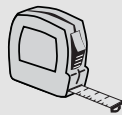

Measuring tape



Pencil

### STEP 2 - Option 1: Installing on a wood stud\* wall

**Note:** Any wallboard or material covering the wall must not exceed 5/8" (16 mm).

- 1 Locate the stud. Verify the center of the stud with an edge-to-edge stud finder.
- 2 Align the wall plate template (J) at the height you determined in the previous step and make sure that it is level. Tape the wall plate template in position, then use a pencil to mark the lag bolt hole locations (2). Remove the wall plate template.
- 3 Drill pilot holes to a depth of 3 in. (75 mm) using a 1/8" (3 mm) wood drill bit.
- 4 Align the wall plate (B) with the pilot holes, insert the lag bolts (G) through the holes in the wall plate, then tighten the lag bolts only until they are firm against the arm assembly.

**CAUTION:** Avoid potential injuries or property damage!  
**DO NOT** over-tighten the lag bolts (G).

\* Minimum wood stud size: common 2 x 4 in. (51 x 102 mm)  
 nominal 1 1/2 x 3 1/2 in. (38 x 89 mm).

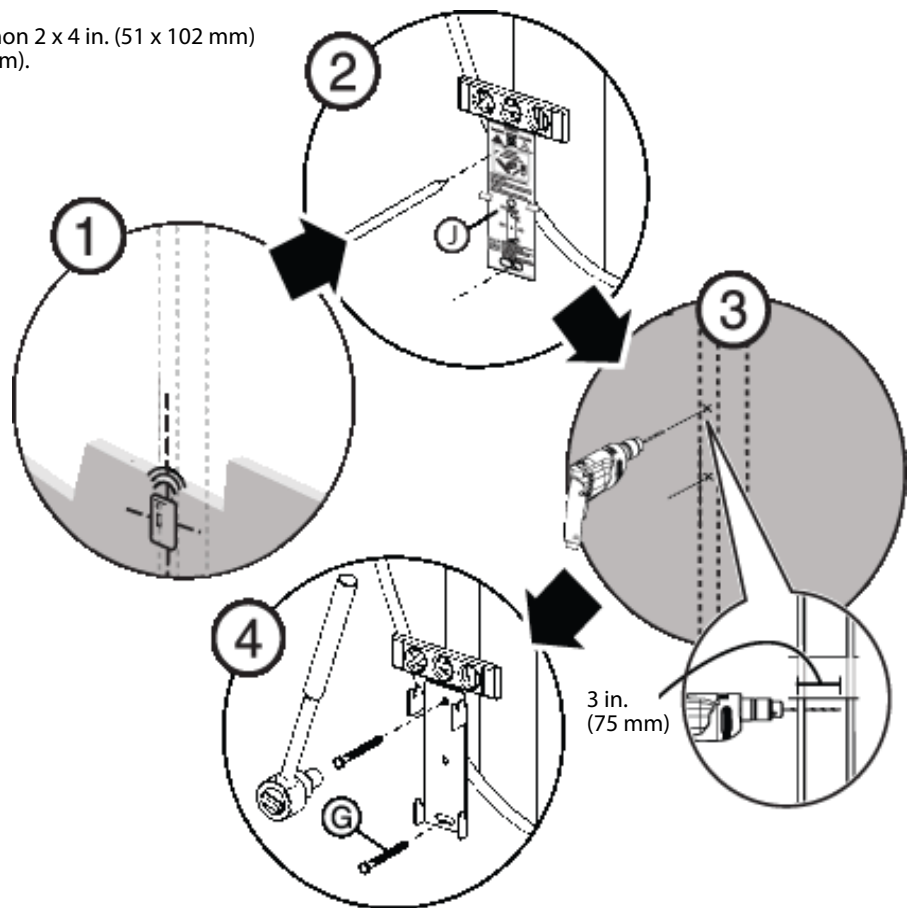

### You'll need

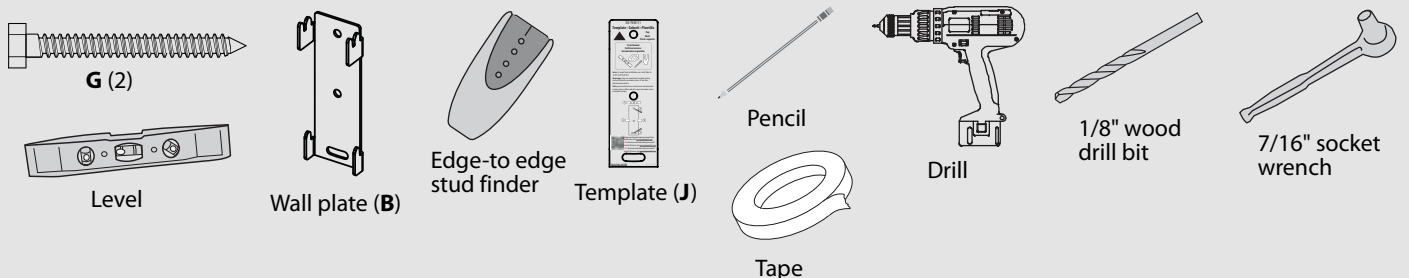

## STEP 2 - Option 2: Installing on a solid concrete\* or concrete block wall

**CAUTION:** To prevent property damage or personal injury, never drill into mortar between blocks. Mount wall plate directly onto the concrete surface.

- 1 Align the wall plate template (J) at the height you determined in the previous step and make sure that it is level. Tape the wall plate template in position, then use a pencil to mark the lag bolt hole locations (2). Remove the wall plate template.
- 2 Drill pilot holes to a depth of 3 in. (75 mm) using a 1/2 in. (12 mm) diameter masonry drill bit.
- 3 Insert the concrete wall anchors (H) into the pilot holes and use a hammer to make sure the anchors are flush with the concrete surface.
- 4 Align the wall plate (B) with the anchors, insert the lag bolts (G) through the holes in the wall plate, then tighten the lag bolts only until they are firm against the wall plate.

**CAUTION:** Avoid potential injuries or property damage!

DO NOT over-tighten the lag bolts (G).

\* Minimum solid concrete thickness: 8 in. (203 mm)

\* Minimum concrete block size: 8 x 8 x 16 in. (203 x 203 x 406 mm)

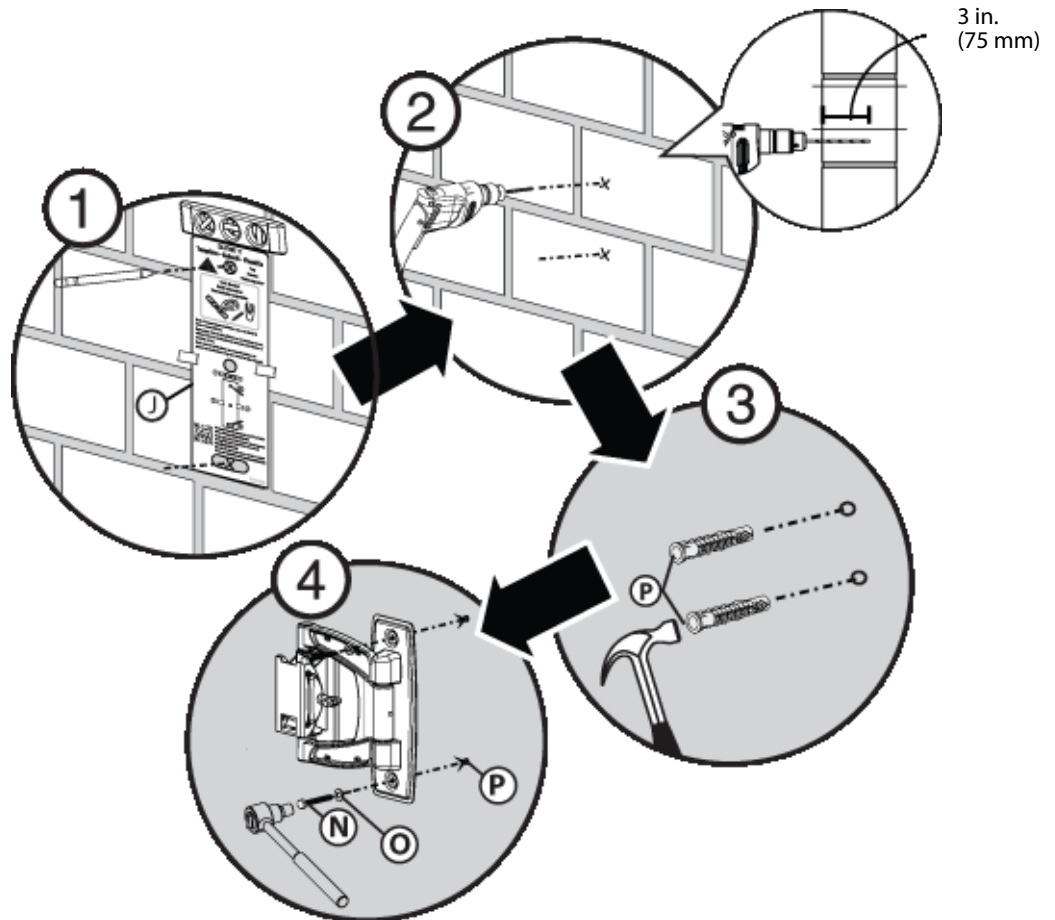

### You'll need

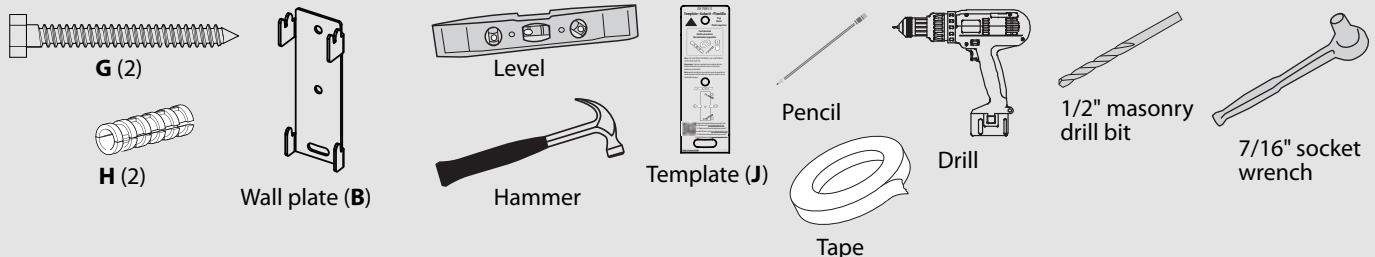

### STEP 3 - Determine whether your TV has a flat, irregular, or obstructed back

- 1 Carefully place your TV screen face-down on a cushioned, clean surface to protect the screen from damages and scratches.
- 2 If your TV has a table-top stand attached, remove the stand. See the documentation that came with your TV for instructions.
- 3 Temporarily lay the TV bracket (A) on the back of your TV.
- 4 Align the screw holes in the TV bracket with the mounting screw holes on your TV.
- 5 Identify which type of back your TV may have:
  - **Flat back:** The bracket lays flush against the back of your TV and do not block any jacks. You do not need spacers when assembling the wall mount.

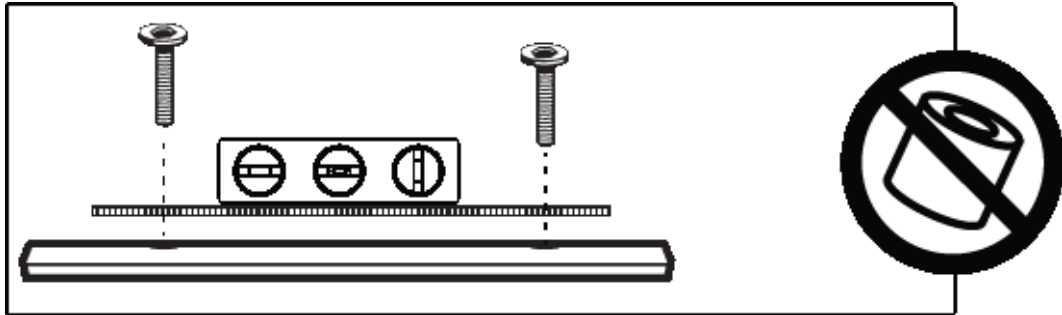

- **Obstructed back:** The bracket blocks one or more of the jacks on the back of your TV. You will need spacers when assembling the wall mount.

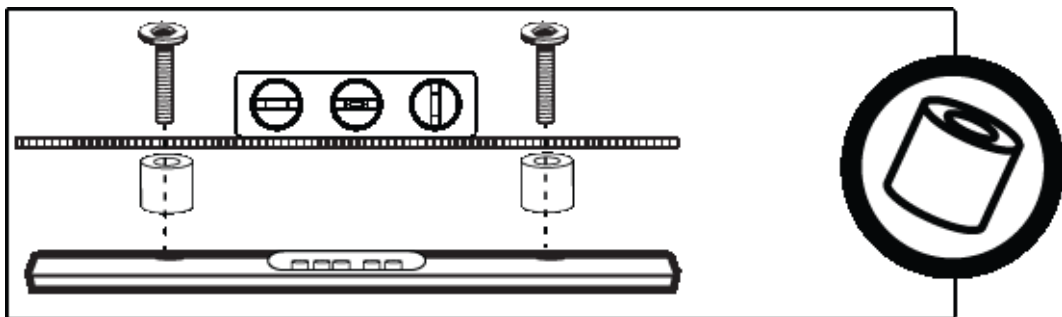

- **Irregularly-shaped back:** There is a gap between the bracket and some part of the back of your TV. You will need spacers when assembling the wall mount.

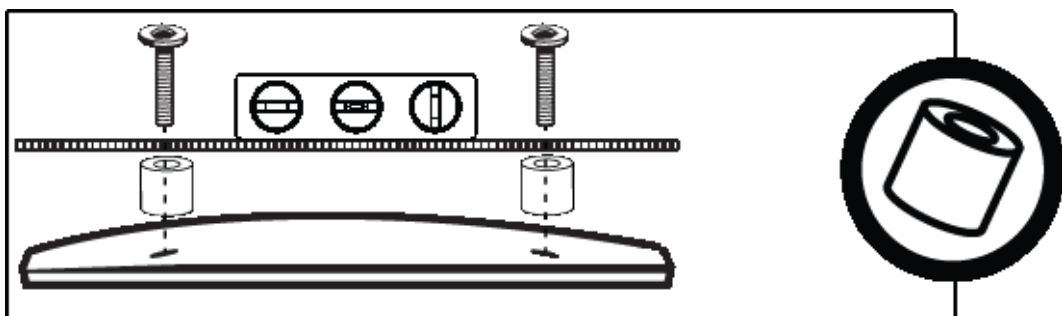

- 6 Remove the TV bracket (A).

## STEP 4 - Select screws, washers, and spacers

- 1 Select the hardware for your TV (screws, washers, and spacers). A limited number of TVs come with mounting hardware included. (If there are screws that came with the TV, they are almost always in the holes on the back of the TV.)

Select one of the following types of screws:

M4 × 12 mm screws (C) for a flat back TV.

M4 × 30 mm screws (D) for an irregular or obstructed TV back.

For an irregular or obstructed TV back, use the following spacers:

Universal spacers (F)

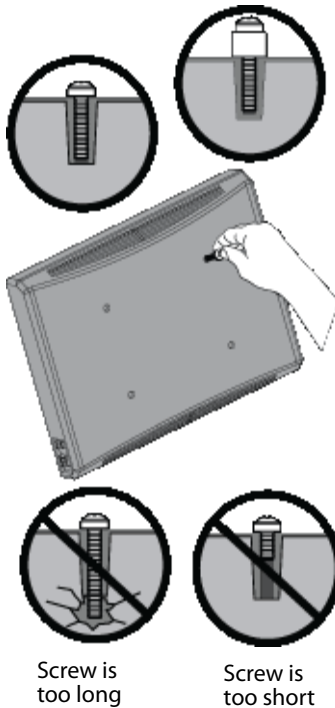

Screw fits correctly

**CAUTION:** To avoid potential personal injuries and property damage, make sure that there are adequate threads to secure the brackets to your TV. If you encounter resistance, stop immediately and contact customer service. Use the shortest screw and spacer combination to accommodate your TV. Using hardware that is too long may damage your TV. However, using a screw that is too short may cause your TV to fall from the mount.

Screw is too long

Screw is too short

- 2 Remove the screws.
- 3 For a flat back TV, go to "STEP 5 - Option 1: Attaching the mounting hardware to TVs with a flat back" on page 9.

-OR-

For an irregular or obstructed back, go to "STEP 5 - Option 2: Attaching the mounting hardware to TVs with irregular or obstructed backs" on page 10.



**STEP 5 - Option 1: Attaching the mounting hardware to TVs with a flat back**

- 1 Align the TV bracket (A) with the screw holes on the back of the TV.
- 2 Install washers (E), and screws (C) into the top two holes in the back of the TV.  
**NOTE:** If the hole pattern on your TV is 75 mm x 75 mm, do not use the washers (E).
- 3 Tighten the screws until they are snug against the TV bracket. Do not over tighten.

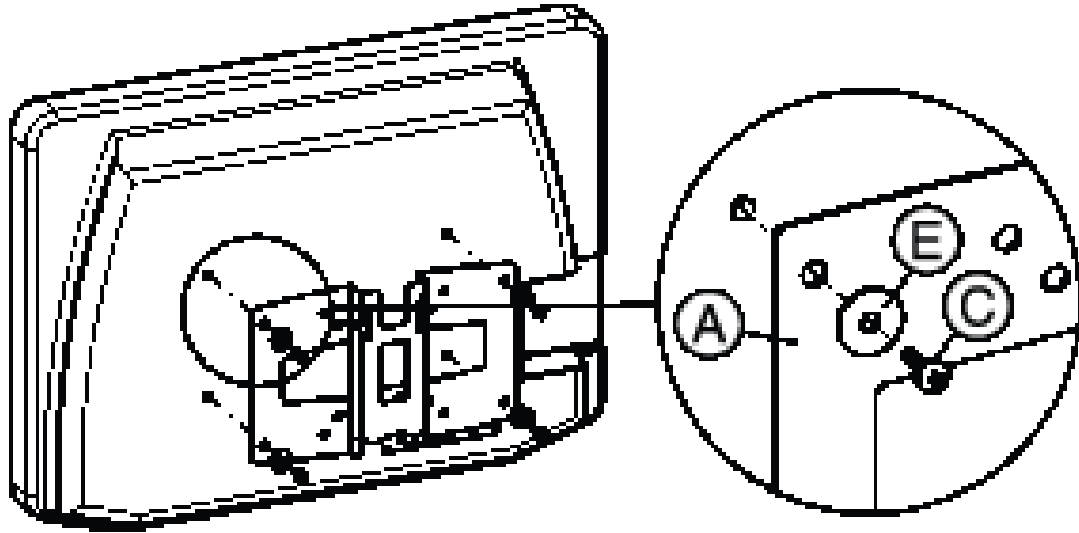
**You'll need****Screws**

C (4)

**Washers**

E (4)

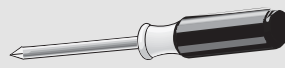

Phillips screwdriver

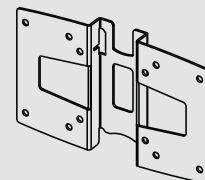

TV bracket (A)

**STEP 5 - Option 2: Attaching the mounting hardware to TVs with irregular or obstructed backs**

- 1 Align the TV bracket (A) with the screw holes on the back of the TV.
- 2 Place spacers (F) behind the TV bracket and the washers (E) over the holes in the TV bracket, then insert the screws (D) through the washers, TV bracket, and spacers.

**NOTE:** If the hole pattern on your TV is 75 mm x 75 mm, do not use the washers (E).

- 3 Tighten the screws until they are snug against the TV bracket. Do not over tighten.

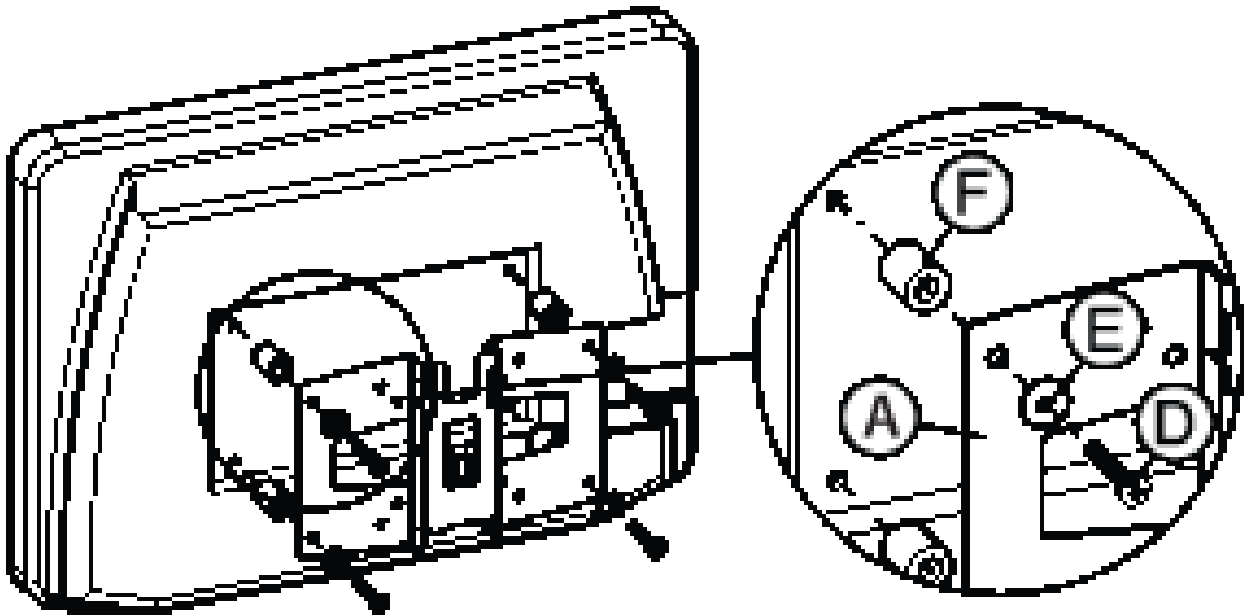
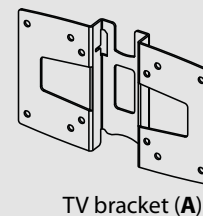
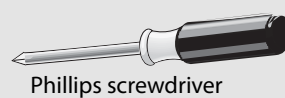
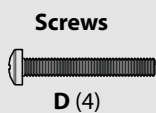
**You'll need**

### STEP 6 - Mounting the TV to the wall plate

- Place the TV bracket (A) into the slotted flanges of the wall plate (B). The TV can be mounted either (1) vertically, or (2) with a 5° tilt.

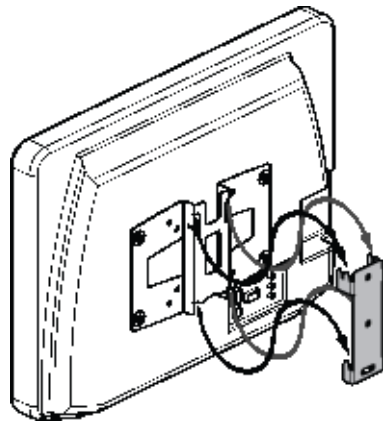

HEAVY! You will need assistance with this step.

#### 1 - Vertical mount

**Note:** Attach the TV bracket to the flange that is closest to the wall plate.

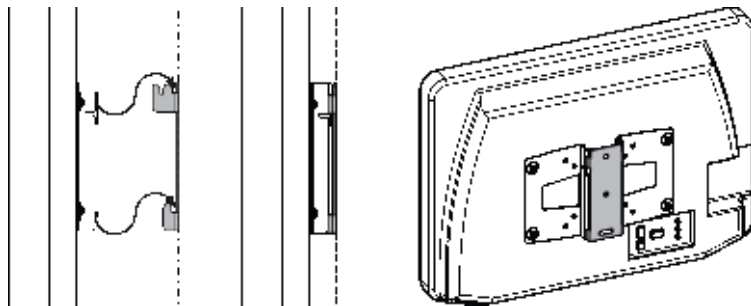

#### 2 - Tilt mount

**Note:** Attach the TV bracket to the flange that is farthest from the wall plate.

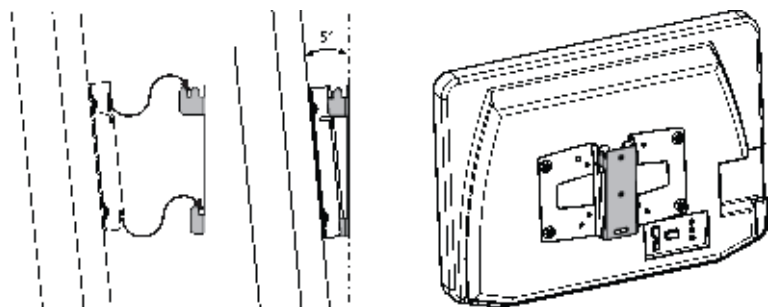

## STEP 7 - Locking the TV to the wall plate

- Slide the locking bar (I) through the TV bracket (A) and the wall plate (B) to secure the TV. A padlock (not included) may be used for extra security.

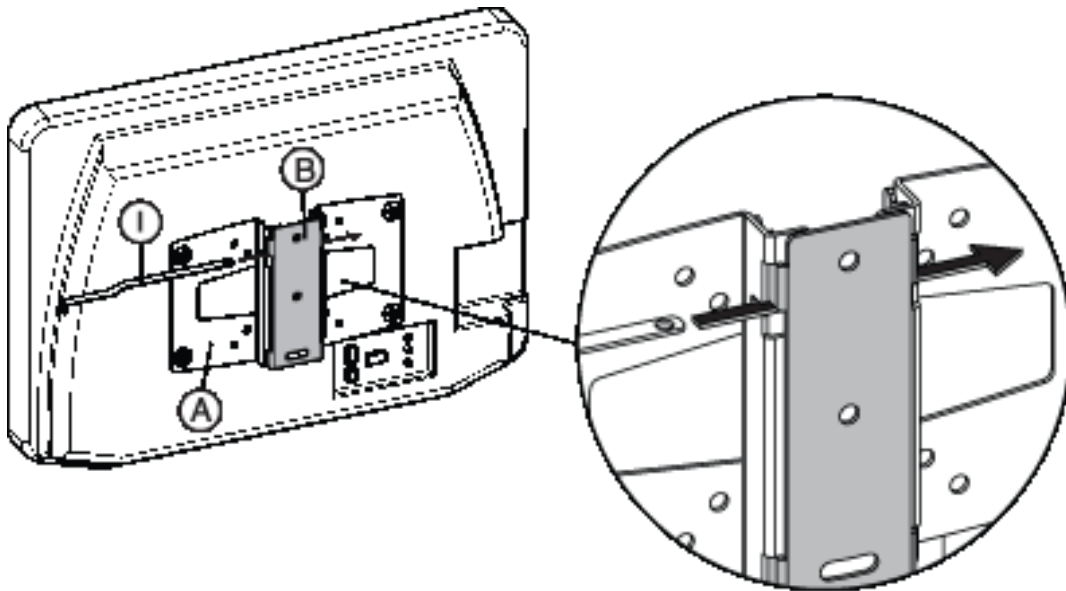

Vertical mount

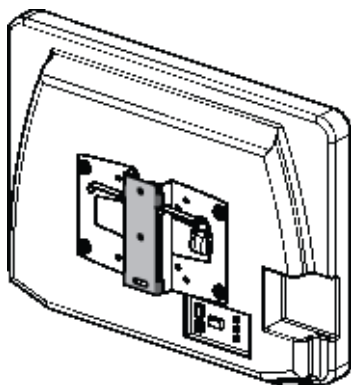

Tilt mount

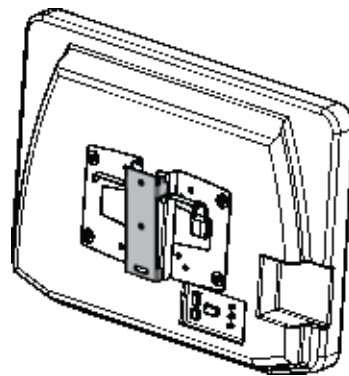

### You'll need



Locking bar (I)

**DY N E X**™

[www.dynexproducts.com](http://www.dynexproducts.com) (800) 305-2204

Distributed by Best Buy Purchasing, LLC  
7601 Penn Ave. South, Richfield, MN 55423 U.S.A.

© 2013 BBY Solutions, Inc. All rights reserved.

DYNEX is a trademark of BBY Solutions, Inc. Registered in some countries. All other products and brand names are trademarks of their respective owners.

6907-002009 <02>